

# Sportlight™

Metal Halide Lamps  
Linear – 1500W and 2000W  
Tubular Clear – 1000W and 2000W  
Internal Ignitor - 2000W

DATA SHEET

## Product information

Sportlight™ lamps are high light output Metal Halide Lamps with high colour rendering index.

## Application



Sport



## Basic data

Nominal Wattage [W]	Rated Wattage [W]	Weighted Energy Consumption [kWh/1000 hrs]	Volts [V]	Cap	Product Description	Product Code	Nominal Lumen [lm]	Rated Lumen [lm]	Rated Lamp Efficacy [lm/W]	Energy Efficiency Class [EEC]	CCT [K]	CRI [Ra]	Mercury Content [mg]	Ambient Temp. [°C]	Operating Position	Average Rated Life [h]	Insertion lamp length [mm]	Pack Qty	
<b>Sportlight™ Linear</b>																			
1500	1500	1672.00	250	RX7SM	SPL1500/L/H/652/Rx7SM	16920	120,000	120,000	80	A	5200	65	47.5	25	HOR±15°	6,000	256	1	
2000	2150	2339.36	230	spec.	SPL2000/L/H/651/SPEC	16922	200,000	200,000	93	A	5100	65	72.0	25	HOR±15°	6,000	311	1	
<b>Sportlight™ Tubular Clear</b>																			
1000	1000	1147.07	120	E40	SPL1000/T/H/960/E40	88882	80,000	80,000	80	A	6000	93	61.5	25	HOR±60°	8,000	340	4	
2000	2000	2294.78	225	E40	SPL2000/380V/T/H/960/E40	30102	170,000	170,000	85	A	6000	93	149.9	25	HOR±60°	5,000	430	4	
2000	1900	2090.00	125	E40	SPL2000/220V/T/H/640/E40	36078	189,000	180,000	90	A+	4000	65	256.0	25	HOR±75°	2,000	430	4	
<b>Sportlight™ Internal Ignitor</b>																			
2000	2000	2182.21	235	E40	SPL2000/380V/I/T/H/640/E40	33148	190,000	190,000	95	A+	4000	65	325.8	25	HOR±75°	2,000	430	4	
2000	2000	2291.96	225	E40	SPL2000/380V/I/T/H/960/E40	30103	170,000	170,000	85	A	6000	93	149.9	25	HOR±60°	5,000	430	4	



## Dimensions

Figure 1.

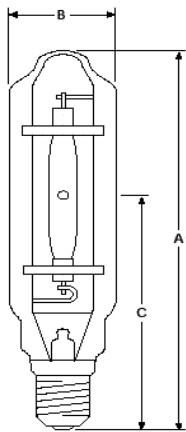

Figure 2.

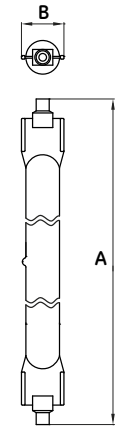

Figure 3.

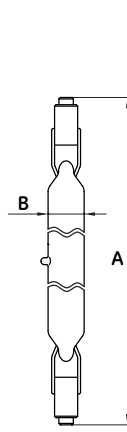
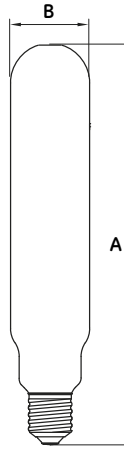

Figure 4.



Type	Wattage (W)	A Contact Length [mm]	B Contact Diameter [mm]	C LCL [mm]	Cap	Bulb Glass	Operating Position	Fig. No.	Minimum Starting Temperature [°C]
SPL1500/L/H/652/Rx7SM	1500	250.7	24.3	N/A	RX7SM	Quartz	Hor. ±15°	2	-30
SPL2000/L/H/651 spec	2000	310	26	N/A	Spec	Quartz	Hor. ±15°	3	-30
SPL1000/T/H/960/E40	1000	333.5	65	229	E40	Hard glass	Hor. ±60°	4	-20
SPL2000/380V/T/H/960/E40	2000	430	101.5	265	E40	Hard glass	Hor. ±60°	1	-20
SPL2000/220V/T/H/640/E40	2000	430	101.5	287	E40	Hard glass	Hor. ±75°	1	-20
SPL2000/380V/I/T/H/640/E40	2000	430	101.5	265	E40	Hard glass	Hor. ±75°	1	-20
SPL2000/380V/I/T/H/960/E40	2000	430	101.5	265	E40	Hard glass	Hor. ±60°	1	-20

## Survival rate and lumen maintenance

The graph shows the survival of representative groups of lamps operated under control conditions at 10 hours per start. Lamp life in service will be affected by a number of parameters, such as mains voltage deviations, switching cycle, luminaire design and control gear. The information given is intended to be a practical guide in determining lamp replacement schedules.

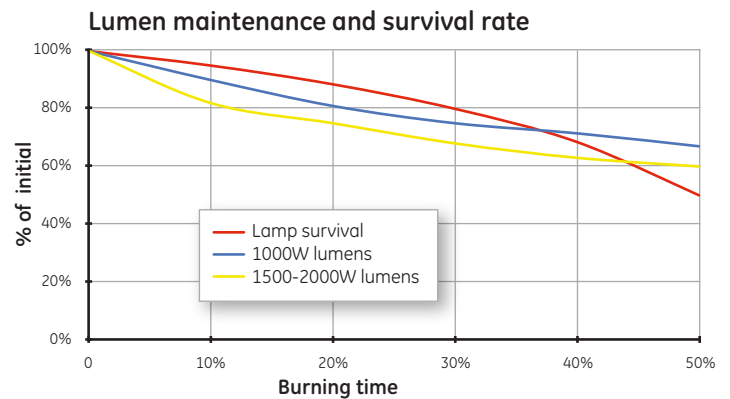

## Electrical data

Data is based on a nominal lamp operating from a nominal choke (reactor) ballast.

Product Description	Lamp Voltage [V]	Current [A]	Power [W]	Maximum Current Crest Factor	Supply Voltage [V]
SPL1500/L/H/652/Rx7SM	250	4.2	1000	1.8	380
SPL2000/L/H/651 Spec	230	10.3	2000	1.8	380
SPL1000/T/H/960/E40	120	9.5	1000	1.8	220
SPL2000/380V/T/H/960/E40	225	10.3	2000	1.8	380
SPL2000/220V/T/H/640/E40	125	16.5	2000	1.8	220
SPL2000/380V/I/T/H/640/E40	235	8.8	2000	1.8	380
SPL2000/380V/I/T/H/960/E40	225	10.3	2000	1.8	380

Note: For ballast characteristics please see page 4.

## Spectral power distribution

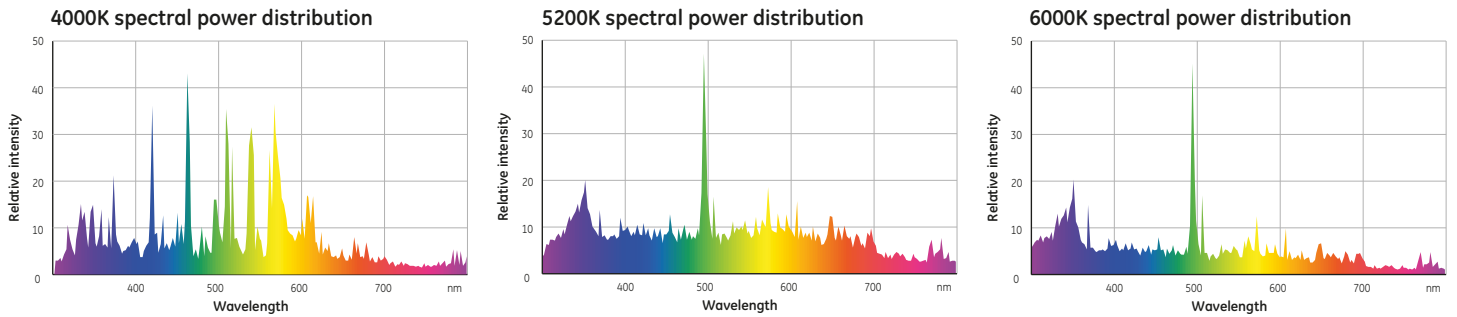

## Operating note

Metal halide lamps operate with a high internal pressure and there is a slight risk that lamps may shatter, particularly if run beyond rated life. At end of life a switch off should be introduced every 24 hours to reduce the risk of shattering. The lamp must be fully enclosed by a luminaire to ensure the retention of any fragments in the event of such failure.

## Run-up characteristics

The graph shows typical run-up characteristics for Spotlight™ lamps. Time for the light output to reach 90% of the final value is determined by supply voltage and ballast design. Typical value is:

Wattage (w)	1000-2000
Run-Up Time (mins)	4

## Hot re-strike time

All ratings re-strike within 16 minutes following a short interruption in the supply. Actual re-strike time is determined by ignitor type, pulse voltage and cooling rate of the lamp.

## Supply voltage

Lamps are suitable for supplies in the range 380V to 420V 50/60Hz for appropriately rated series choke (reactor) ballasts. Lamps start and operate at 10% below the rated supply voltage when the correct control gear is used. However, in order to maximise lamp survival, lumen maintenance and colour uniformity the supply voltage and ballast design voltage should be within  $\pm 3\%$ . Supply variations of  $\pm 5\%$  are permissible for short periods only. This may be achieved by measuring mean supply voltage at the installation and selecting ballasts with appropriate settings.

## Control gear

There are no international standards for metal halide lamps of this type. It is therefore important to check the compatibility of lamp and control gear. Detailed information is given under "Guidance for luminaire manufacturers" overleaf. It is essential to use a ballast appropriate to the supply voltage at the luminaire. Typical wiring diagrams for control circuits incorporating "superimposed" ignitor and choke (reactor) ballast are shown. Refer to actual choke and ignitor manufacturers data for terminal identification and wiring information.

Typical run-up characteristics

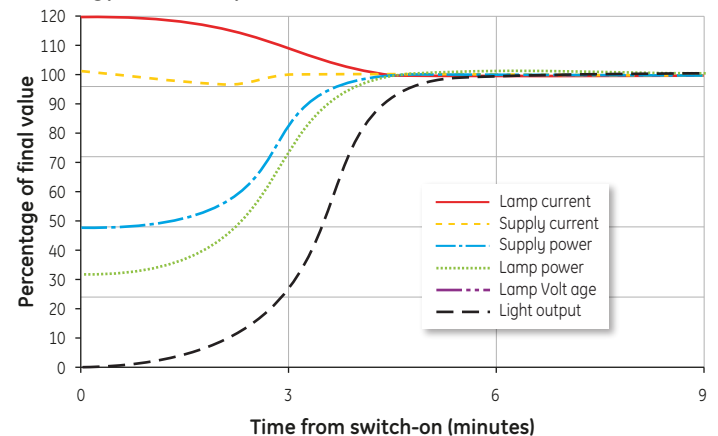

Typical superimposed ignitor circuit

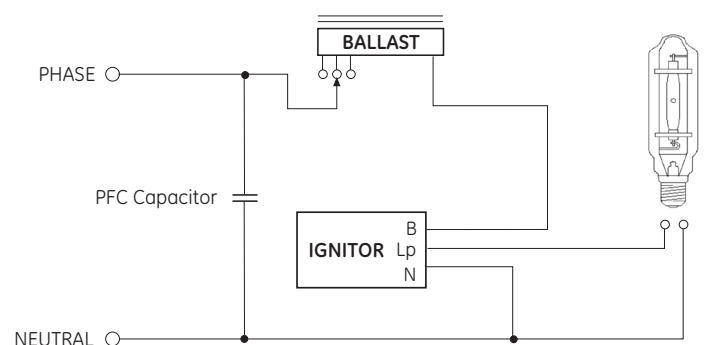

## Fusing of circuits

For a very short period after switch-on, all discharge lamps may act as a partial rectifier and as a result the ballast may allow several times the normal supply current to flow. For further information refer to the publication "Fuse Ratings for Discharge Lamps" available from GE Lighting.

## Lamp operating temperature limits

Maximum cap temperature: 250°C

Maximum bulb temperature: 550°C

## Control gear

To achieve correct lamp starting, performance and life it is important that lamp and control gear are compatible and suitably rated for the supply voltage at the luminaire.

## Ballasts

Ballasts should comply with specifications IEC61347-1 and IEC60923. Series choke (reactor) ballasts should have characteristics close to the following values:

Product Description	Current [A]	Supply Voltage [V]	Impedance [V/A]
SPL1500/L/H/652/Rx7SM	6.8	380	34.4
SPL2000/L/H/651 spec	10.3	380	25.6
SPL1000/T/H/960/E40	9.5	220	17
SPL2000/380V/T/H/940/E40	10.3	380	25.5
SPL2000/220V/T/H/640/E40	16.5	220	9.25
SPL2000/380V/I/T/H/640/E40	8.8	380	28
SPL2000/380V/I/T/H/960/E40	10.3	380	25.5

**Ballast thermal protection** — use of ballasts incorporating thermal cut-out is not a specific requirement but is a good optional safety measure for the installation.

**Ballast voltage adjustment** — series choke (reactor) ballasts incorporating additionalappings at  $\pm 20V$  of the rated supply voltage are recommended. Alternatively a single additional tapping 20V above the rated supply voltage will ensure lamps are not overloaded due to excessive supply voltage.

## PFC capacitors for choke (reactor) circuits

Power factor correction is advisable in order to minimise supply current and electricity costs.

## Cable between ignitor and lamp

To achieve good starting superimposed ignitors must be adjacent to the luminaire. Cable capacitance of wiring between the ignitor "Lp" terminal and the lamp should not exceed 100pF (<1 metre length) when measured to adjacent earthed metal and/or other cables, unless otherwise stated by the ignitor manufacturer.

## Ignitors

Superimposed type ignitors are suitable. It is recommended that only GE approved ignitors are used. Ignitors should comply with specifications IEC61347-2 and IEC60927 and have starting pulse characteristics as follows:

Product Description	Voltage [V] <sup>1</sup>	Voltage [V] <sup>2</sup>	Width [ $\mu$ s] <sup>3</sup>	Repetition Rate <sup>4</sup>	Current [A]
SPL1500/L/H/652/Rx7SM	4,000	5,500	1	1-6/cycle	0.2
SPL2000/L/H/651/Spec	4,000	5,500	1	1-6/cycle	0.2
SPL1000/T/H/960/E40	4,000	5,000	1	1/cycle	0.2
SPL2000/380V/T/H/960/E40	4,000	5,000	1	1/half cycle	0.2
SPL2000/220V/T/H/640/E40	4,000	5,000	1	1/cycle	0.2

1. When loaded with 100 pF
2. When loaded with 20pF
3. At 90% peak voltage
4. From ignitor into lamp during starting

Pulse Phase Angle: 60-90°el and/or 240-270° el. Timed Ignitors—Use of a "timed" or "cut-out" ignitor is not a specific requirement but it is a good optional safety feature for the installation. The timed period must be adequate to allow lamps to cool and restart when the supply is interrupted briefly (see "Hot Re-strike Time"). A period of 5 minutes continuous or intermittent operation is recommended before the ignitor is automatically switched off. Commercially available 10/11 minute timed ignitors are suitable.